

MULTI PRODUCTS CO.  
RACINE WIS.

SPEC. VOLTS

LEADS:  
15" FREE LENGTH  
2-BLACK

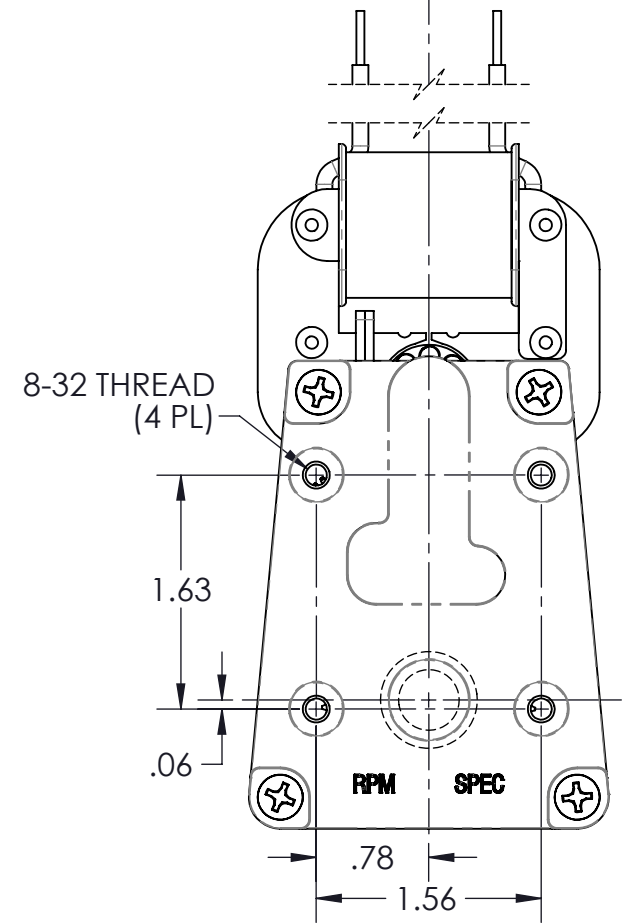
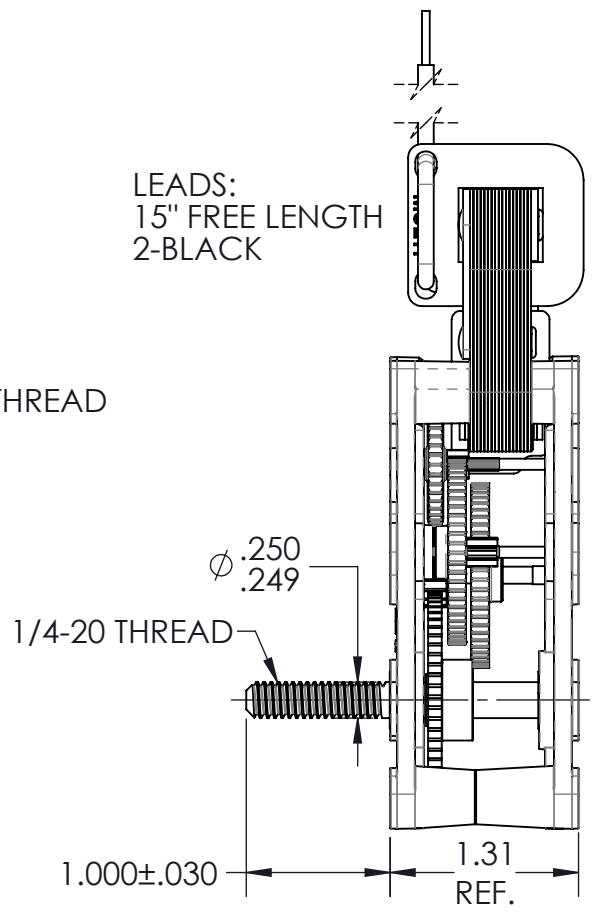

RPM SPEC

RATED VOLTAGE: 120 VAC, 60 Hz  
ROTATION: CCW  
NO LOAD SPEED: 3.2 RPM  
NO LOAD CURRENT: 0.16 A

LOADED SPEED @ 5 IN-LB: 2.8 RPM  
LOADED CURRENT @ 5 IN-LB: 0.16 A  
STALL TORQUE: 14 IN-LB  
STALL CURRENT: 0.16 A

I/WE CERTIFY THAT SAMPLES OF THIS MOTOR HAVE BEEN FULLY TESTED BY THE UNDERSIGNED AND THAT ALL SPECIFICATIONS HAVE BEEN REVIEWED FOR PRODUCTION. MULTIPRODUCTS COMPANY, INC. IS NOT RESPONSIBLE FOR MOTORS THAT FAIL IN THE FIELD DUE TO INSUFFICIENT TESTING OF THE SAMPLE MOTORS. I/WE AGREE TO PROVIDE MULTIPRODUCTS COMPANY, INC. WITH CURRENT DRAWINGS AND IN-HOUSE TEST PROCEDURES AS THEY BECOME AVAILABLE. ANY CHANGES THAT I/WE MAY MAKE WHICH OCCUR AFTER THE DATE SHOWN ARE SUBJECT TO REVIEW AND MAY AFFECT UNIT PRICE AND/OR DELIVERY DATES.

A	REDRAWN	3/12/2019	
REV.	DESCRIPTION	DATE	ECO#

**TOLERANCES**

- X.XX: ±.010
- X.XXX: ±.005
- FRACTION: ±1/64
- ANGLE: ±2°

UNLESS OTHERWISE SPECIFIED



**MULTI PRODUCTS**  
Company, Inc.

PART NAME/DESCRIPTION: **GLENRAY / TOMLINSON**

DRAWN BY: DAB	DATE: 3/12/2019	SCALE: 0.75:1	MATERIAL: SEE BOM
CHK'D BY: DMR	DATE: 3/12/2019	PART NUMBER: <b>MOD-240</b>	
APPR'D BY: RP	DATE: 3/12/2019		

SIGNATURE \_\_\_\_\_ PRINT NAME \_\_\_\_\_ DATE \_\_\_\_\_  
IN ORDER TO BEGIN PRODUCTION, MULTIPRODUCTS COMPANY, INC. MUST HAVE SIGNED APPROVAL.